

Belmont Board v2

Bittium

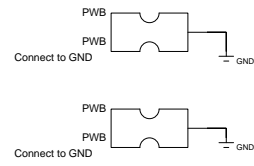

PAGES	PAGES
➔ Nucleo board interfacer1	
➔ Nucleo board interface2	
➔ PWR, Sensor & UI	
➔ Modem 1	
➔ Modem 2	
➔ GNSS 1	
➔ GNSS 2	
➔ Debug	

Nucleo board interface 1

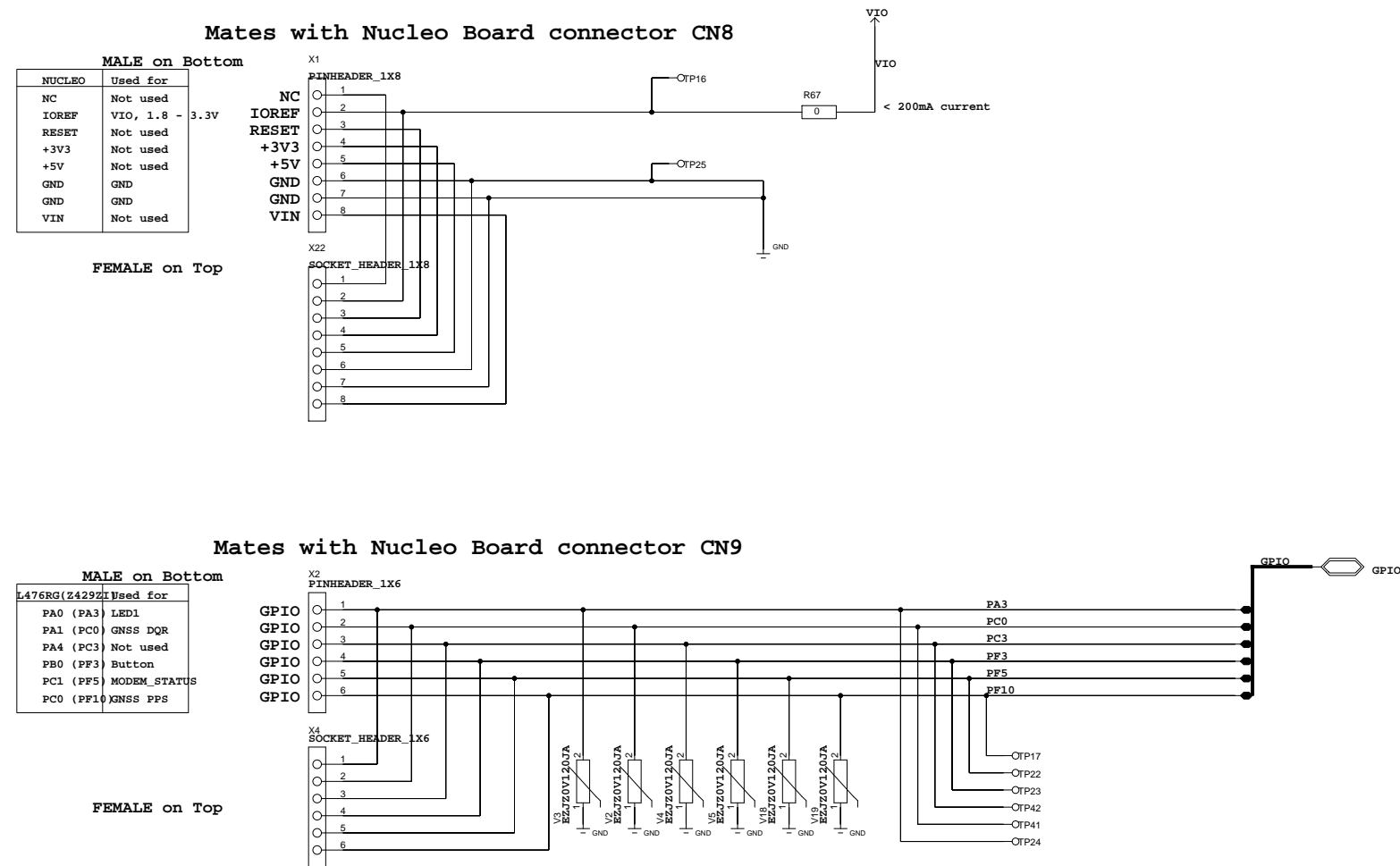

Dwg Num	Sheet name: Nucleo board interface1	Project	121401	History
Bitium	Scale	A3H	Designer	Designer
	Sheet	2 of 9	Editor	Editor
Unit/Mod	Unit	Date	28/06/2017:16:35	Appr.
Product	Product	Descr.	ConnectivityBoard	Version
Delivery	Delivery			0.1

Nucleo board interface 2

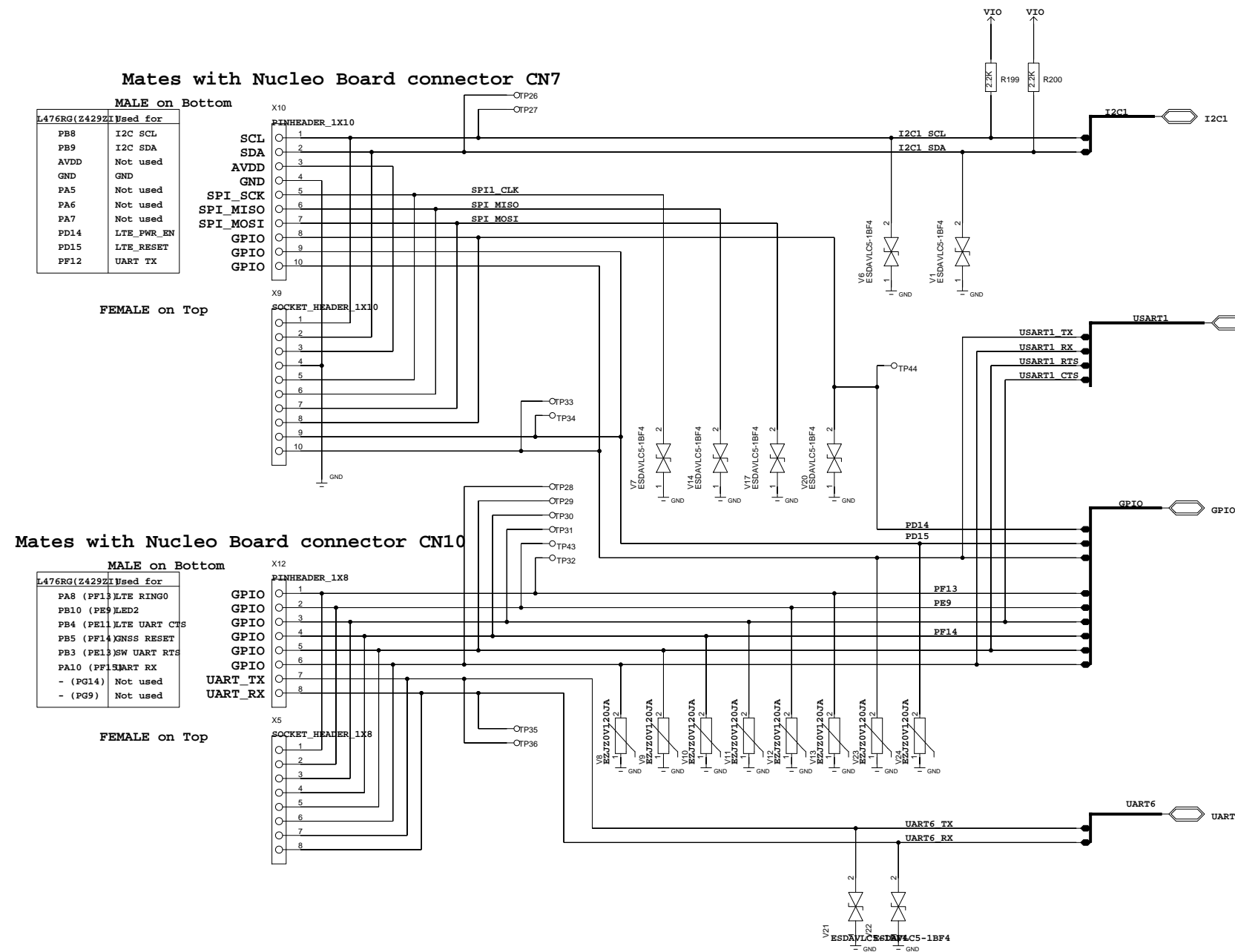

Dwg Num	Sheet name	Project	History
	Nucleo board interface2	121401	Date Version
Bitium		Scale	A3H
		Sheet	3 of 9
Unit/Mod	Unit	Date	28/06/2017:16:41
Product	Product	Descr.	ConnectivityBoard
Delivery	Delivery	Version	0.1

PWR, Sensor & UI

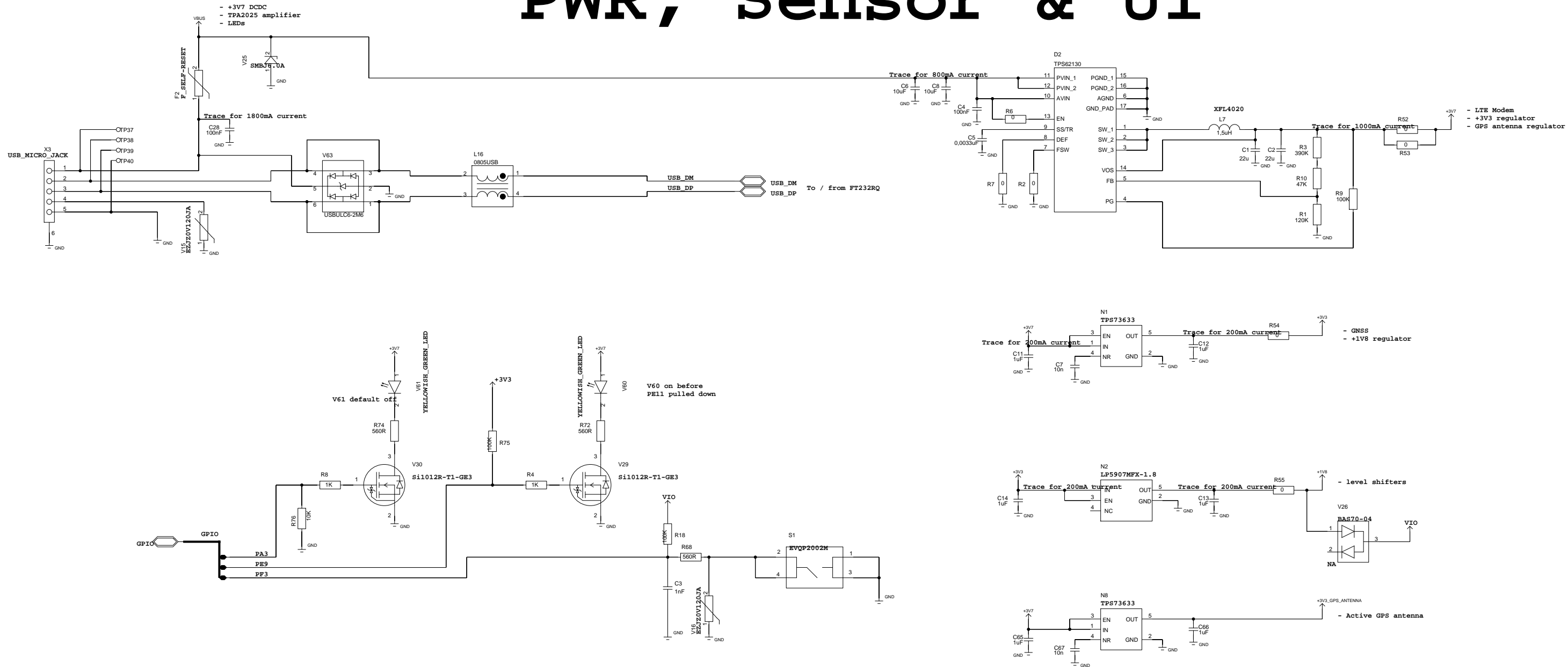

Dwg Num	Sheet name: PWR	Project	121401	History
Bitium	Scale	A3H	Designer	Designer
	Sheet	4 of 9	Editor	Editor
Unit/Mod	Unit	Date	29/06/2017:11:08	Appr.
Product	Product	Descr.	ConnectivityBoard	Version
Delivery	Delivery			0.1

Modem 1

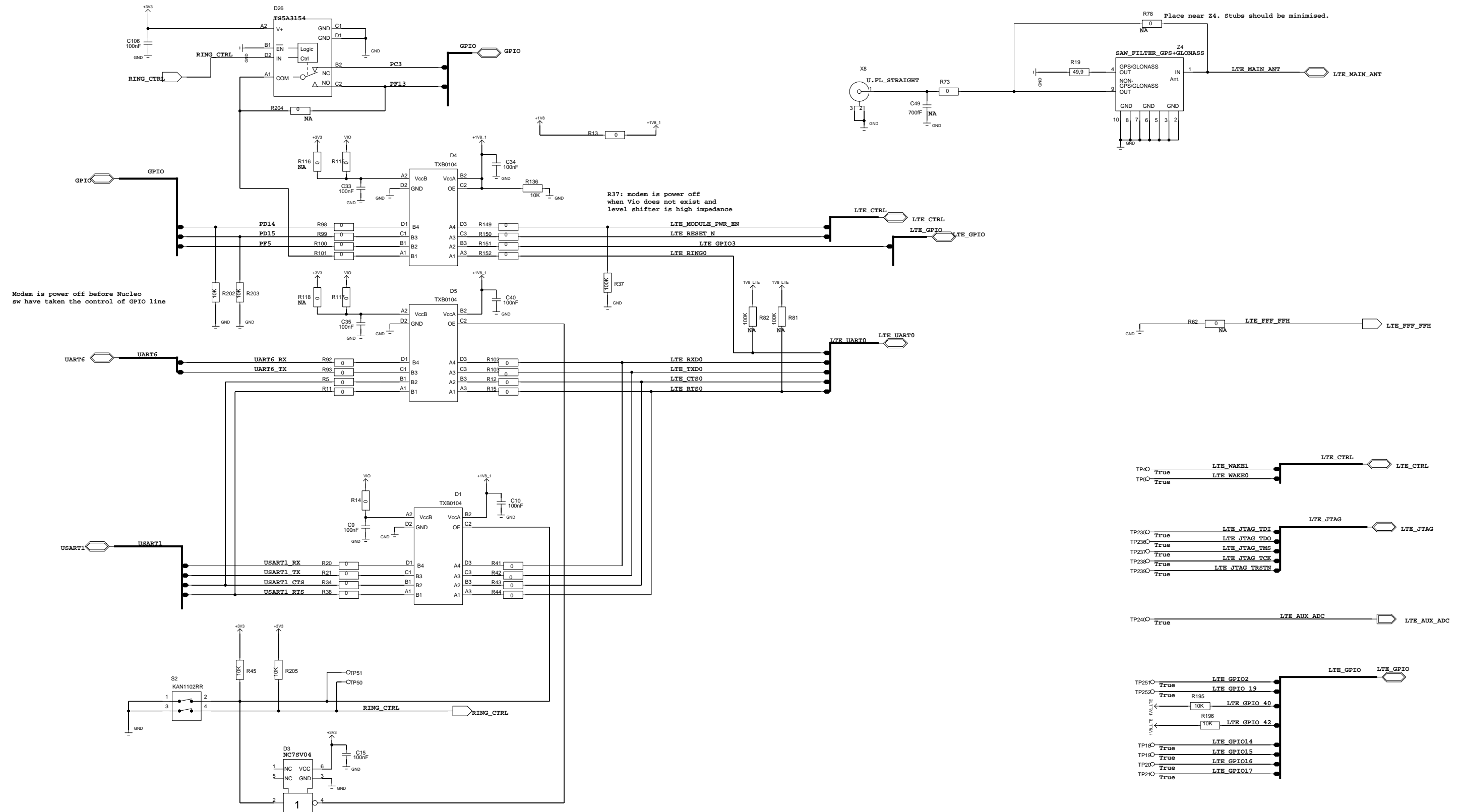

Dwg Num	Sheet name:	Project	History
	Modem 1:2	121401	Date Version
Bitium	Scale A3H	Designer Designer	
	Sheet: 6 of 9	Editor Editor	
Unit/Mod	Unit	Date 29/06/2017:10:56	Appr. Approver
Product	Product	Descr. ConnectivityBoard	Version 0.1
Delivery	Delivery		

Modem 2

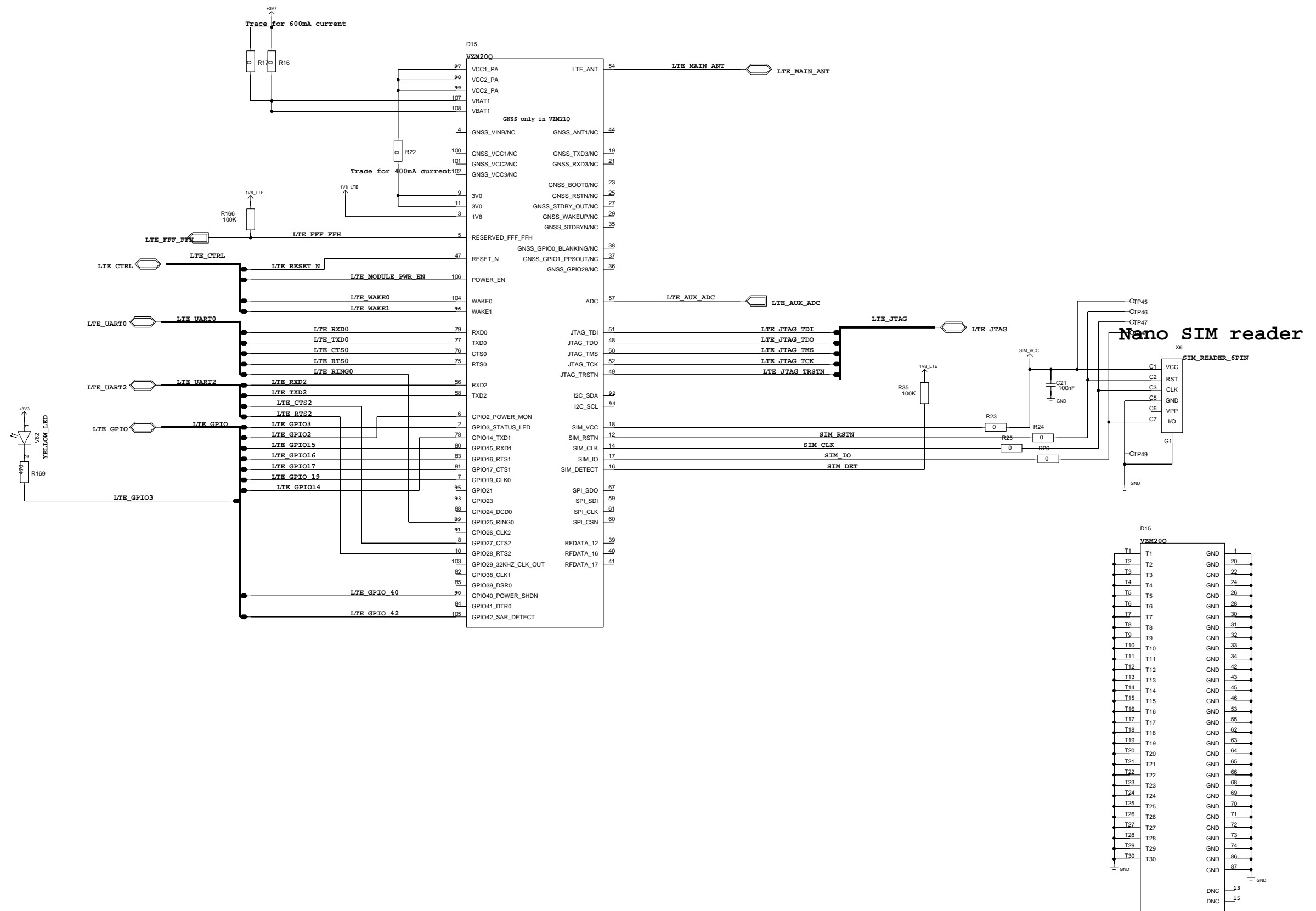

Dwg Num	Sheet name:	Project	History
	Modem 2:2	121401	Date Version
Bittium	Scale A3H	Designer Designer	
	Sheet: 7 of 9	Editor Editor	
Unit/Mod	Unit	Date 28/06/2017:16:12	Appr. Approver
Product	Product	Descr. ConnectivityBoard	Version 0.1
Delivery	Delivery		

GNSS 1

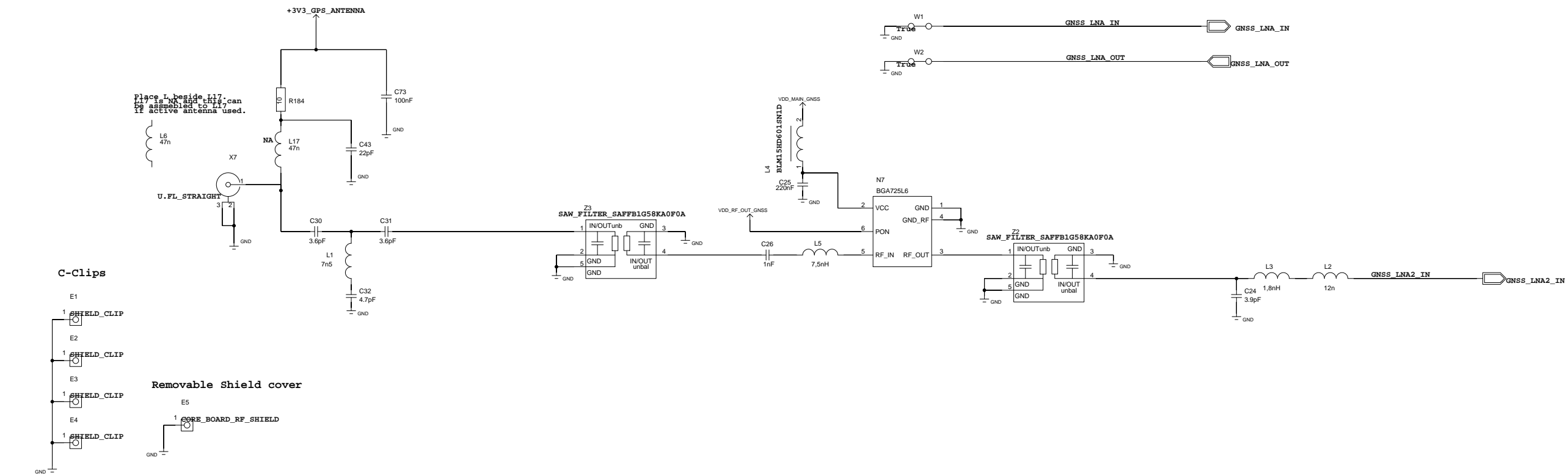
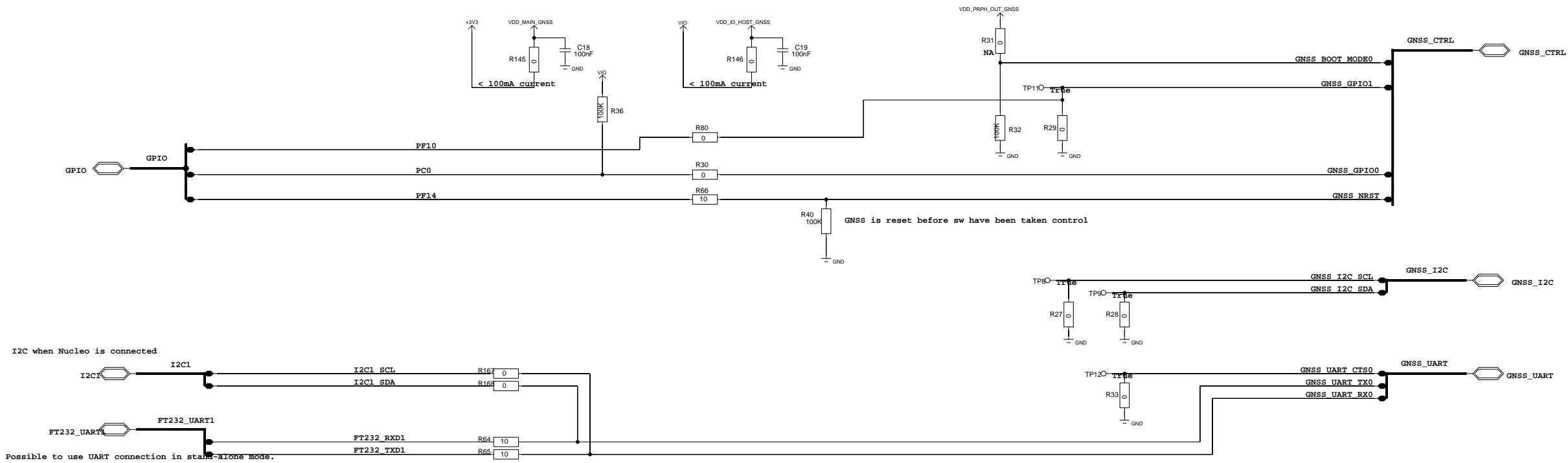

Dwg Num	Sheet name: GNSS 1:2	Project	121401	History
Bittium	Scale	A3H	Designer	Designer
	Sheet	8 of 9	Editor	Editor
Unit/Mod	Unit	Date	28/06/2017:16:04	Appr.
Product	Product	Descr.	ConnectivityBoard	Version
Delivery	Delivery			0.1

GNSS 2

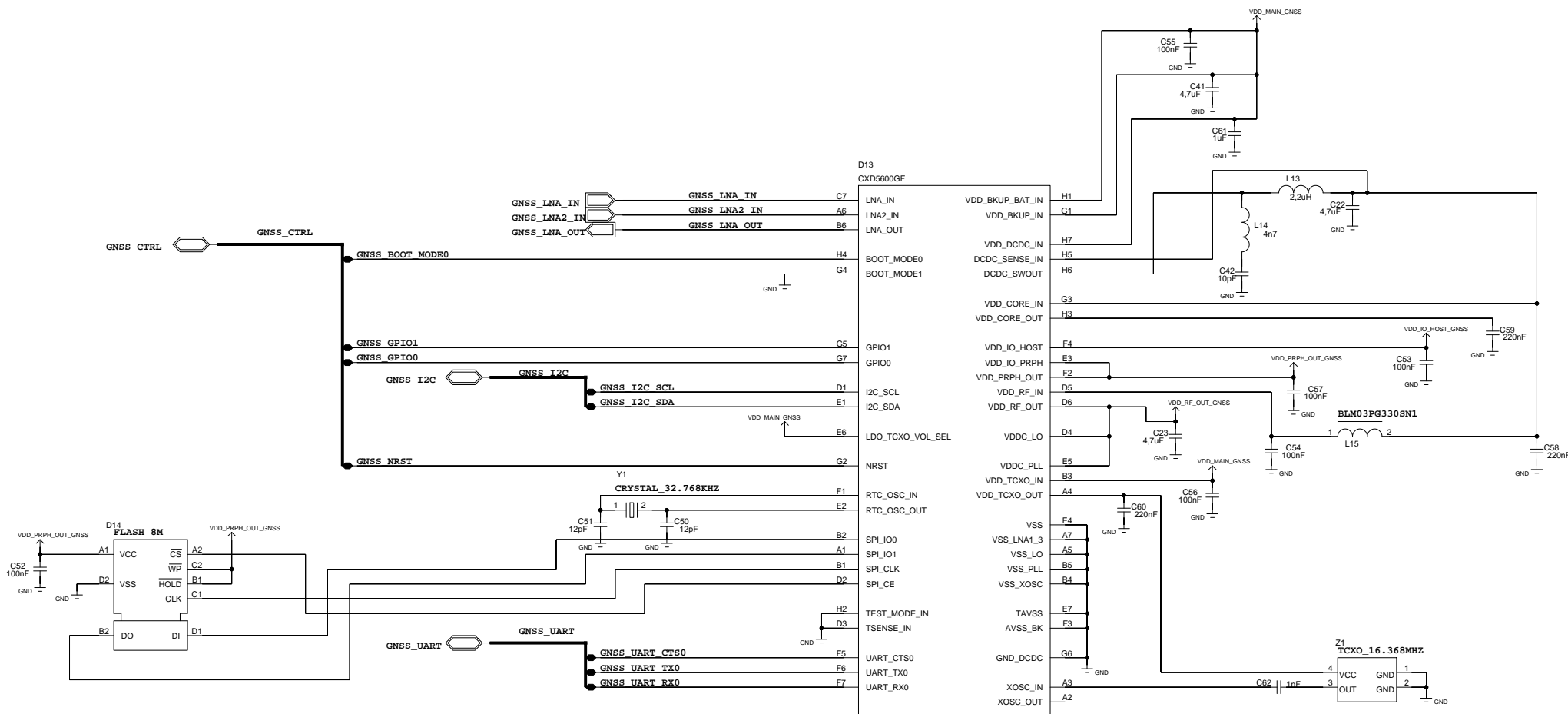

Device	I2C Address
GNSS	0 x 0100 100x

x = Read/Write bit

Dwg Num	Sheet name: GNSS 2:2	Project	121401	History
Bitium	Scale	A3H1	Designer	Designer
	Sheet	9 of 9	Editor	Editor
Unit/Mod	Unit	Date	20/06/2017:15:00	Appr.
Product	Product	Descr.	ConnectivityBoard	Version
Delivery	Delivery			0.1

Debug

All connections are for debugging of V1 and might be removed in future versions.

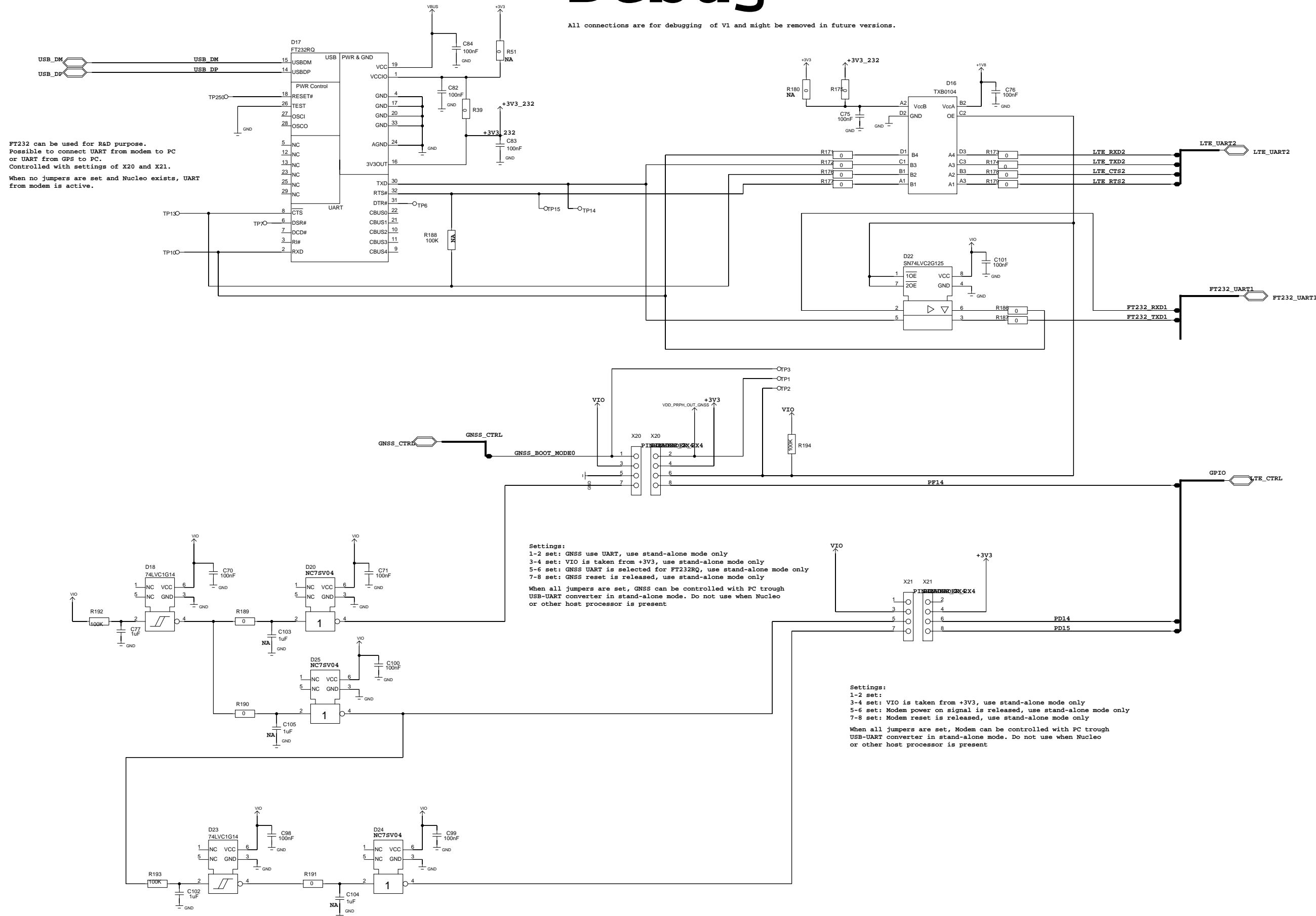

FT232 can be used for R&D purpose.
Possible to connect UART from modem to PC
or UART from GPS to PC.
Controlled with settings of X20 and X21.
When no jumpers are set and Nucleo exists, UART
from modem is active.

Settings:
1-2 set: GNSS use UART, use stand-alone mode only
3-4 set: VIO is taken from +3V3, use stand-alone mode only
5-6 set: GNSS UART is selected for FT232RL, use stand-alone mode only
7-8 set: GNSS reset is released, use stand-alone mode only
When all jumpers are set, GNSS can be controlled with PC through
USB-UART converter in stand-alone mode. Do not use when Nucleo
or other host processor is present

Settings:
1-2 set:
3-4 set: VIO is taken from +3V3, use stand-alone mode only
5-6 set: Modem power on signal is released, use stand-alone mode only
7-8 set: Modem reset is released, use stand-alone mode only
When all jumpers are set, Modem can be controlled with PC through
USB-UART converter in stand-alone mode. Do not use when Nucleo
or other host processor is present

Dwg Num	Sheet name: Debug	Project	121401	History
Bitium	Scale	A3H	Designer	Designer
	Sheet:	of 10	Editor	Editor
Unit/Mod	Unit	Date	20/06/2017:15:18	Appr.
Product	Product	Descr.	ConnectivityBoard	Version
Delivery	Delivery			0.1